



105 Bonnie Drive
Butler, PA 16002
724-283-4681
724-283-5939 (fax)
www.bwieagle.com

PRODUCT INFORMATION BULLETIN

VR SENSOR Variable Reluctance Type MODELS 10-7003, 10-7008, 10-7032

DESCRIPTION

The Eagle® Variable Reluctance (VR) Sensor is designed to measure signals from any rotating apparatus and transmit this information by low-voltage 2-conductor twisted pair cable back to an Eagle control unit located up to 2 miles away. This sensor can easily be identified by its bright red end-cap(s).

THEORY OF OPERATION

The Eagle Variable Reluctance sensor senses a target as it passes through the magnetic field of the internal pick-up coil, hence the term "variable reluctance".

The target has to break the magnetic field fast enough to create an induced voltage in the coil, therefore, the minimum sensing speed is approximately 60 RPM. **Adding additional targets will not increase the minimum sensing speed of the sensor!**

The sensing distance from a target is directly proportional to the speed of the roller.. (i.e. – At 60 RPM this sensor will detect a 1/2" target at 1/64". The same target and sensor at 100 RPM will be detected at approximately 1/4").

INSTALLATION

1. Select the roller or shaft to be monitored. If a roller is to be monitored, be sure it is always contacting the belt.
2. Affix a target on the roller or shaft. Target should be a piece of key stock, 1/4-20 Hex Nut, etc. (Figure 1) Dents and notches are not recommended as targets.
3. Mount sensor firmly with hose clamps or U-bolts to prevent it from moving or working loose. Tape is **NOT** recommended as a fastener.
4. Before tightening, place sensor close enough to the target(s) to produce a strong, steady blinking on the sensor-head LED. The LED should blink in direct proportion to the roller speed. Effective distance between sensor and target(s) is approximately 1/64 inch to 3/4 inch depending on target mass and roller speed.

SPECIFICATIONS

Model 10-7003	
Dimensions	4 in. x 1.3 in. O.D.
Sensor Type	Variable Reluctance Failsafe Output
Housing / Mounting	PVC / General Mount
Sensor Power Requirement	Current limited 12 VDC from Control Unit
Sensor Cable	Unshielded Twisted Pair 16/2 - 50 Ft. with Connector
Distance	Sensor to Control Unit - 2 Miles MAX
Sensing Speed Range	60 RPM – 800 RPM
Model 10-7008	
Dimensions	4.91 in x 1.30 in O.D.
Sensor Type	Variable Reluctance Failsafe Output
Housing / Mounting	PVC / Conduit Mount
Sensor Power Requirement	Current limited 12 VDC from Control Unit
Sensor Cable	Unshielded Twisted Pair 16/2 - 3' Pigtail
Distance	Sensor to Control Unit - 2 Miles MAX
Sensing Speed Range	60 RPM – 800 RPM
Model 10-7032	
Dimensions	4.12 in. x 1.32 in. O.D.
Sensor Type	Variable Reluctance Failsafe Output
Housing / Mounting	Threaded PVC / Conduit or Bracket Mounting
Sensor Power Requirement	Current limited 12 VDC from Control Unit
Sensor Cable	Unshielded Twisted Pair 16/2 - 3' Pigtail
Distance	Sensor to Control Unit - 2 Miles MAX
Sensing Speed Range	60 RPM – 800 RPM

FIGURE 1

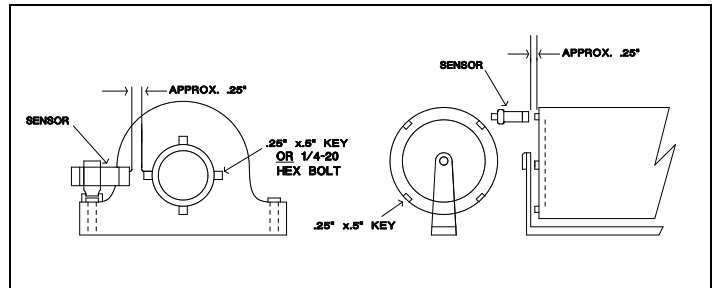

VR SENSOR

Variable Reluctance Type

MODELS 10-7003, 10-7008, 10-7032

10-7003 DIMENSIONS

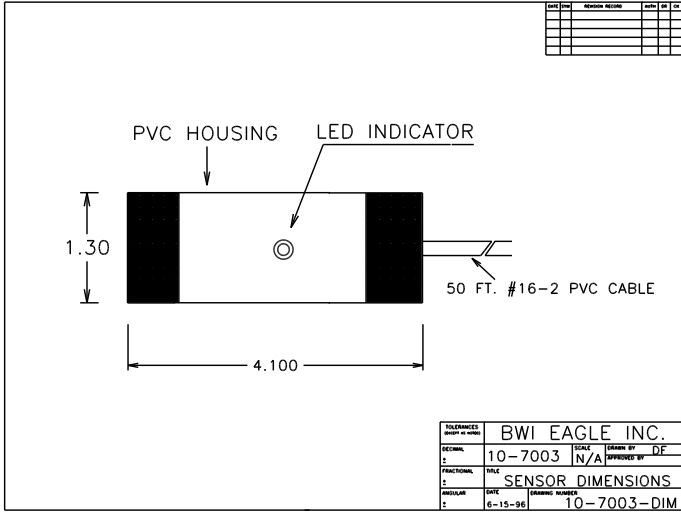

10-7032 DIMENSIONS

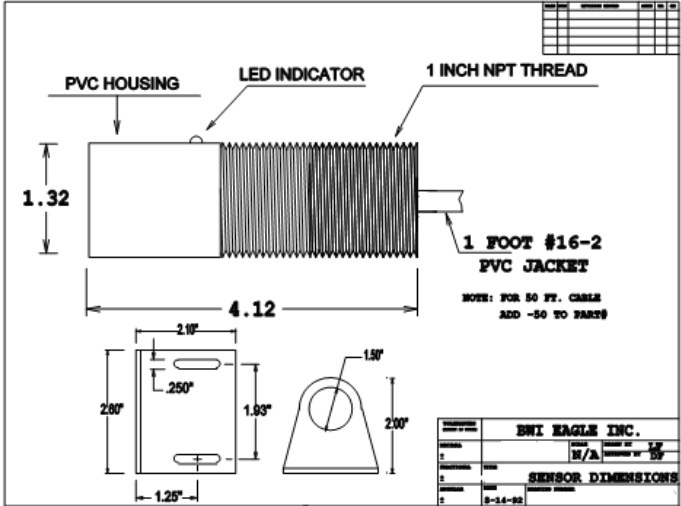

10-7008 DIMENSIONS

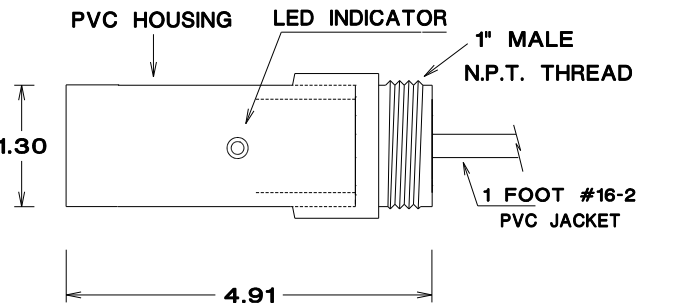

DOCUMENT DATE: 1/24/2022

 105 Bonnie Drive
 Butler, PA 16002
 (724) 283-4681
 Fax (724) 283-5939
www.bwieagle.com